

# POSITIVE AIR UNITS

SEVERAL OPTIONS AND SIZES ARE AVAILABLE TO SUIT ANY APPLICATION.

COMBINES A RAM I-30 WITH A NATURAL OR PROPANE GAS BURNER TO PROVIDE EFFECTIVE TEMPERING AND PRESSURIZED CIRCULATION.

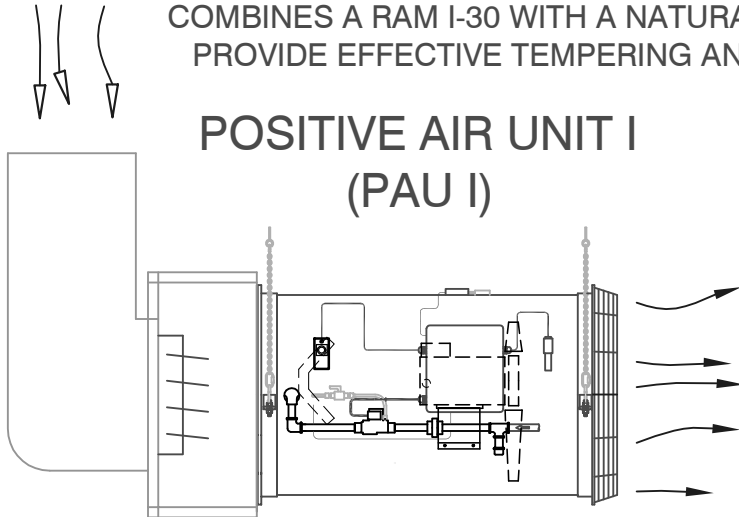

**POSITIVE AIR UNIT I  
(PAU I)**

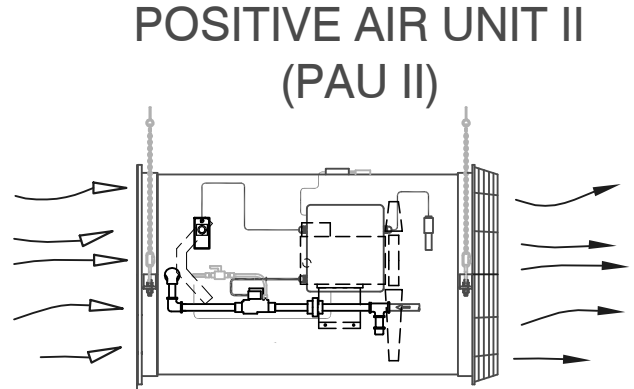

**POSITIVE AIR UNIT II  
(PAU II)**

THE PAU I - POSITIVE AIR UNIT INCLUDES A CIRCULATION HOOD FOR FRESH AIR INTAKE FROM ANOTHER ROOM OR THE OUTSIDE. HOODS CAN BE PLACED IN A WALL OR ON THE ROOF.

LIKE THE PAU I, BUT THE PAU II DOES NOT INCLUDE A FRESH AIR INTAKE.

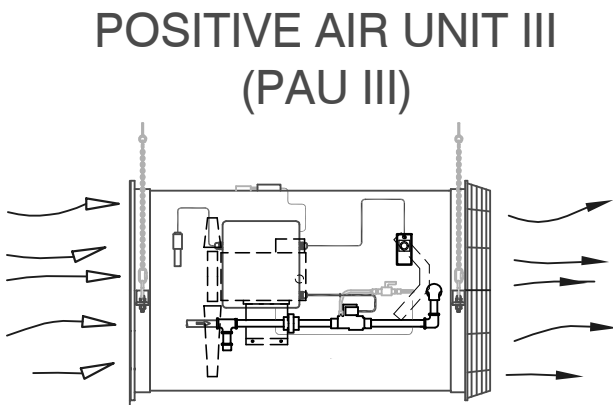

**POSITIVE AIR UNIT III  
(PAU III)**

THE PAU III USES A REVERSED MOTOR SET BEHIND THE BURNER FOR HIGHER OPERATING TEMPERATURES.

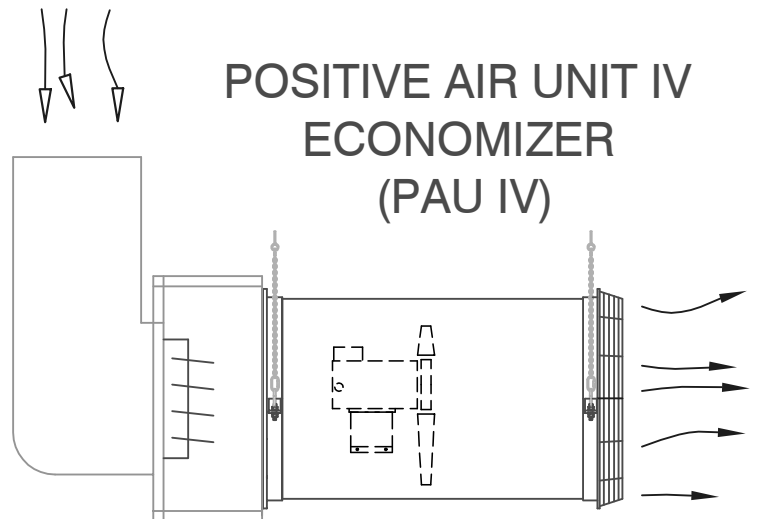

**POSITIVE AIR UNIT IV  
ECONOMIZER  
(PAU IV)**

THE POSITIVE AIR ECONOMIZER DRAWS IN FRESH AIR, CIRCULATES INSIDE AIR, OR BOTH. (NO BURNER)